

PRESEKAR

PRODAJA IN SERVIS OPREME

Špruha 42
1236 Trzin
Slovenia

Tel.: +386 1 56 44 770
Mob.: +386 41 638 609
Fax: +386 1 56 44 772



www.presekar.eu

prodaja@presekar.com
aleksander.presekar@presekar.com

CASCOS



1-post lifts



FABRICANTE EUROPEO DE ELEVADORES

EUROPEAN CAR LIFT MANUFACTURER

FABRICANT EUROPÉEN DE PONTS ÉLÉVATEURS





Homologaciones



Approvals



Homologations

Agradecemos a los principales fabricantes de automóviles que hayan homologado y confíen en los elevadores CASCOS para sus fábricas y redes de concesionarios.

We are very grateful to the large automotive companies who homologates and rely on our lifts for their factories and associated workshops.

Nous sommes reconnaissants à toutes les grandes entreprises d'automobiles qui homologuent et comptent sur nos ponts élévateurs pour leurs usines et centres de maintenance.



Mercedes-Benz



RENAULT



PEUGEOT

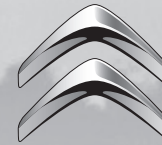

CITROËN



Fábrica Vitoria / Vitoria factory

Certificaciones / Certifications / Certifications



Colaboraciones / Collaborations / Collatorations



Spain



Spain

Utilizamos materiales altamente resistentes y de máxima calidad para fabricar elevadores robustos, fiables y duraderos.

We use highly resistant and first quality materials to build strong, reliable and long life lifts.

Nous utilisons des matériaux hautement résistants et de première qualité pour construire des ponts élévateurs solides, fiables et longue durée

Materiales Materials Materiaux

2

Producción / Montaje Production / Assembly Production / Assemblage

Como fabricantes controlamos todos los procesos de producción y montaje de nuestros elevadores.

As manufacturers we monitor each process of productions and assembly to ensure the highest quality of our lifts.

Comme des fabricants nous surveillons chaque processus de production et d'assemblage pour assurer la meilleure qualité de nos ponts.

3

Controles de calidad Quality controls Contrôles de qualité

Para Cascos la calidad no es una meta, sino un camino por recorrer.

Quality is not a goal, is an ongoing process.

La qualité n'est pas un but mais une préoccupation permanente.

La calidad de nuestros elevadores está certificada por:

The quality of our lifts has been certified by:

La qualité de nos ponts a été certifiée par:

4

Servicio postventa/instalación After sales service/instalation Service après-vente/instalation

5

Diseñamos pensando en las ventajas técnicas de uso y las incorporamos a nuestros elevadores

We focus our designs on technical use advantages incorporating them to our lifts.

Nous concentrons nos designs sur les avantages d'utilisation technique en les intégrant à nos ponts élévateurs.

Diseño/Innovación Design/Innovation Conception/Innovation

1

Priorizamos clientes satisfechos sobre compradores puntuales.

Red de servicios técnicos homologados.
Programas de formación continua.

Compromiso de atención en 24-48 horas.

Contratos de mantenimiento y asistencia técnica.

Garantía de 6 meses en las reparaciones.

Gran Stock de recambios disponible.

We aim long term customers instead of buyers.

Homologated Technical Service.

Ongoing Training Programs.

Committed Customer Services in within 24/48 hours.

Maintenance and Technical Assistance Contracts.

6 months warranty on repairs.

Wide Stock of spare parts.

Nous privilégions les clients fidèles aux acheteurs ponctuels

Service technique homologué.

Programmes d'entrainement continus.

Service client réactif et disponible sous 24 à 48 heures.

Contrat de maintenance et d'assistance technique.

6 mois de garantie sur les réparations.

Large stock de pièces détachées.

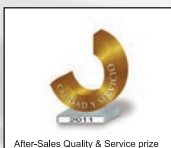

After-Sales Quality & Service prize



Parking



2 Tn

1 columna post colonne

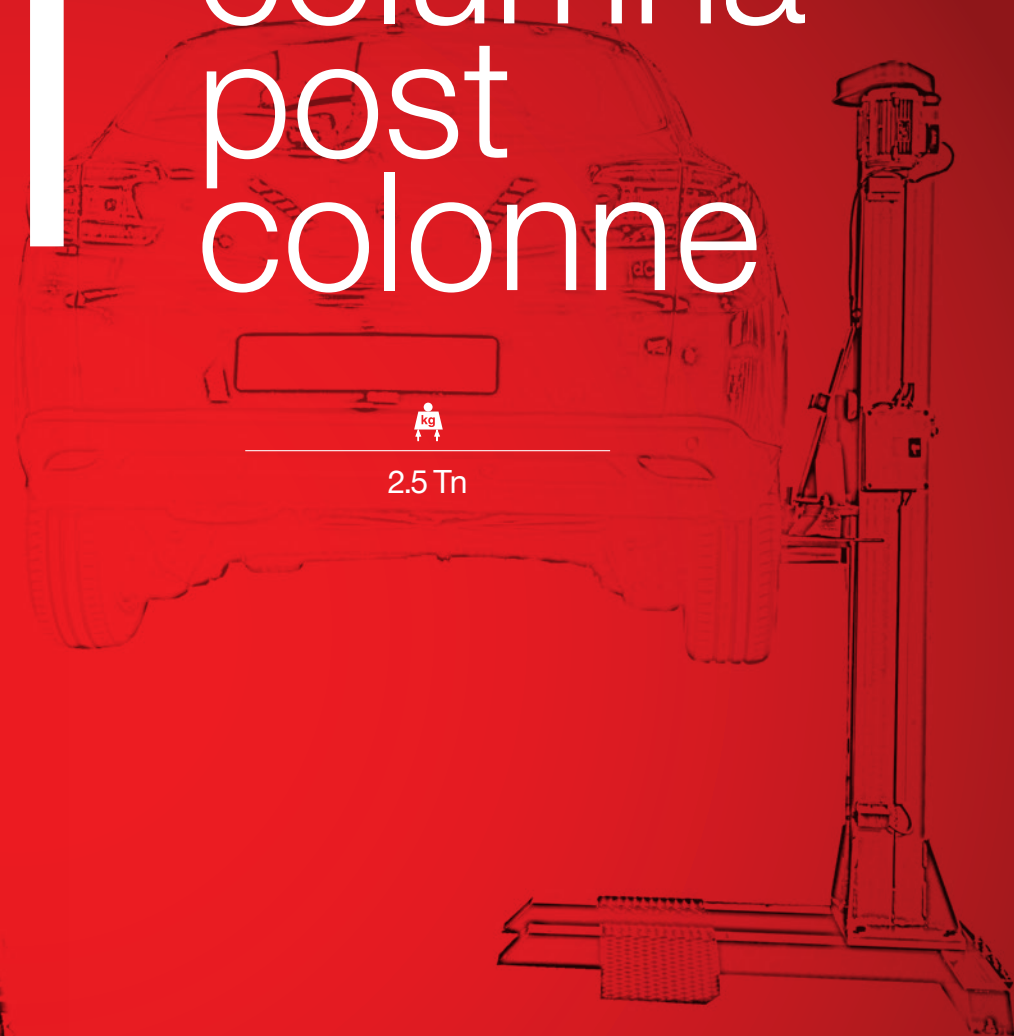

2.5 Tn



Soluciones para
espacios de
trabajo reducidos

DISPONIBLES EN VERSIÓN
MONOFÁSICA



Solutions
for tight
workspaces

AVAILABLES IN SINGLE-PHASE
VERSION







Solutions pour les
petites espaces de
travail

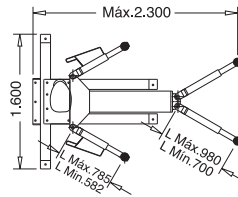
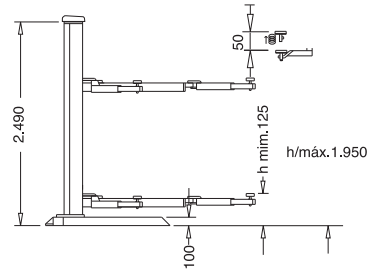

DISPONIBLES EN VERSION
MONOPHASÉE





2.5 Tn

CASCOS



-  Elevadores fabricados con la misma tecnología y aportando las mismas ventajas que los dos columnas.
-  Post lifts made with the same technology and with the same features and advantages than the 2 post lifts.
-  Ponts élévateurs fabriqués avec la même technologie et les mêmes avantages que les deux colonnes.

Monocolumna 
 Single post lift 
 Monocolonne 



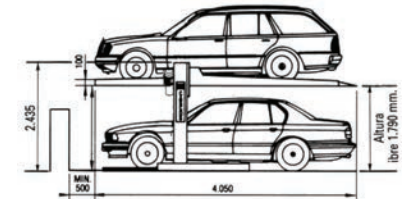
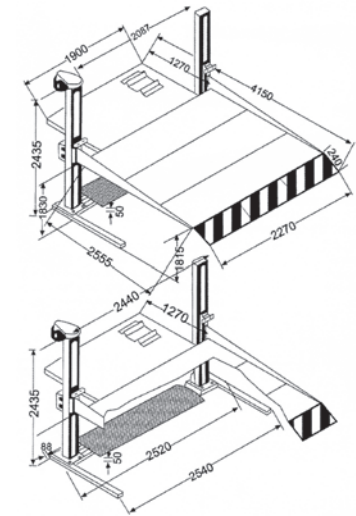
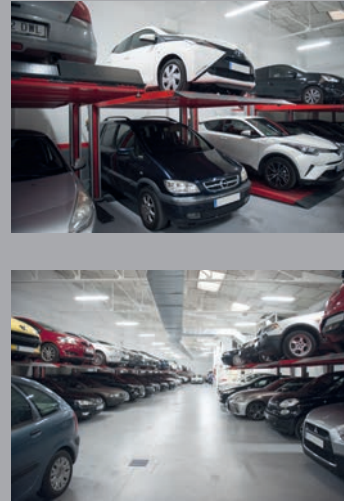

Ref.	C125	C125
	2.500 Kg.	2.500 Kg.
	600 Kg.	600 Kg.
	400 kW/230 Hz	230 Hz
	45"	45"

2 Tn

CASCOS



Elevador parking 
 Parking lift 
 Pont élévateur parking 

Ref.	2 x 1	2 x 1
	2.000 Kg.	2.000 Kg.
	850 Kg.	850 Kg.
	400 kW/230 Hz	230 Hz
	45"	45"